

# Organic **Response**

User manual

**FAGERHULT**

## Contents

Organic Response – Basic Functions .....	3
Relay function .....	3
Factory settings.....	3
Organic Response programming app .....	4
IR interface for smartphones.....	4
Programmable functions .....	5
Times and light levels .....	6
Default settings (personality).....	6
Explanation of menu.....	7
Factory settings .....	7
Explanation of relay function.....	8
Temporary dimming .....	9
Pre-programmed settings (personality).....	10-11
Setting the time after last presence detected (Dwell time).....	12
Daylight dimming .....	13
Simulating a wall panel .....	13
Zoning.....	14
Relay programming information .....	15
Zone X.....	16
Identifying zones used.....	16
Configuring scenes.....	17-18
Organic Response wall panel.....	19
EnOcean Wireless Push button panel .....	20-24
Read an EnOcean switch.....	25
Wireless communication between nodes without IR link.....	26-27
Infrared transmission.....	28
Sensor node settings.....	28
Other parameters.....	29
Disaster Recovery Mode .....	30

## Organic Response

Organic Response is an intelligent lighting control system based on distributed information between the sensors. The system is optimised for large offices or similar spaces. Communication between the sensors is based on infrared light, similar to regular remote controls. The signal from one sensor, which detects presence, is distributed via the floor to other sensors nearby. These sensors transmit the information further, but include a change to not adjust up to full light, but rather a lower level. The distribution continues with the same effect so that the light does not unnecessarily switch on too often.

In order to secure communication between the light fittings below constraints has to be taken into consideration during installation:

Installation height 2.7–3.7 meters.

Distance between luminaires 1.0 – 3.0 meters.

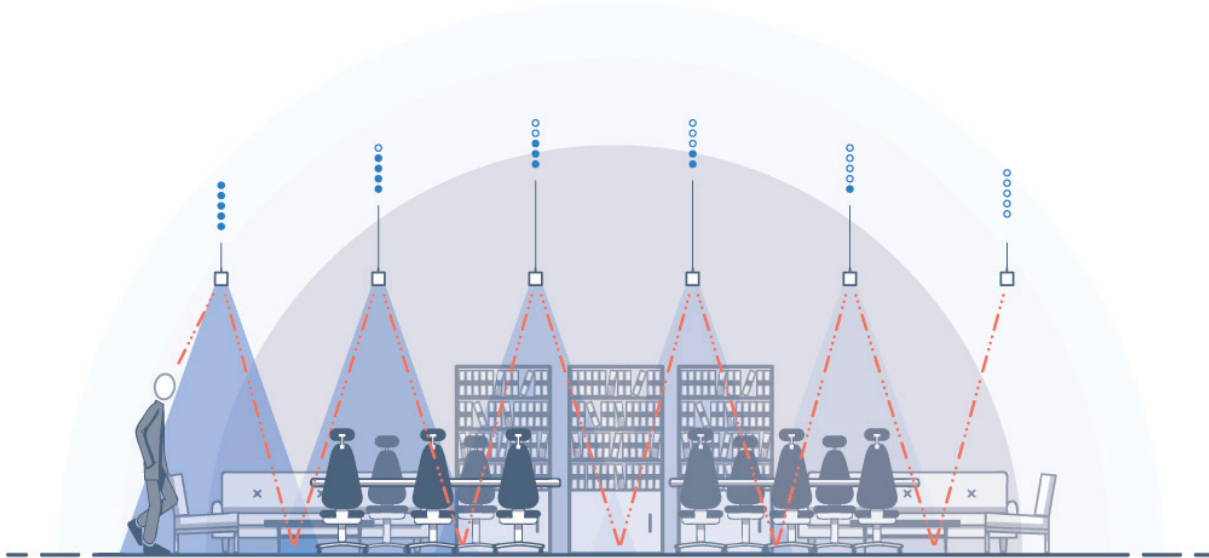

The system functions immediately after power is supplied to the luminaires. No programming is required during the installation stage.

## Relay function

An important and unique feature in Organic Response is the ability to transfer information between sensors, without physical interconnection. In daily use, this relates to information about presence, but, when programming the system, such information can also be “relayed” to other luminaires.

## Factory settings

Upon delivery, the factory settings can be used in an office environment. The time after last presence, and followed by low level is 10 + 10 minutes. If presence is detected again at any time during the intervals, the time is reset. Max. illumination is 100%.

The sensor is equipped with multiple functions. A PIR sensor for presence detection, IR transmitter, IR receiver and a light sensitive diode for measuring brightness. It also has two LEDs which indicate whether a certain function is enabled.

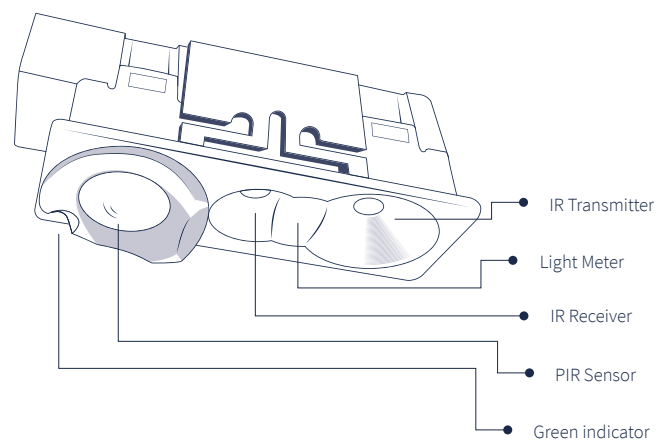

## Access to Organic Response programming app

The Organic Smartphone app is a simple, intuitive user application for optimising an Organic Response installation. An entire office with luminaires can be optimised within minutes by pressing a few buttons. The app can be downloaded from the App Store or Google Play and includes programming assistance and links to manuals. Immediately after downloading the app, you sign in to your LinkedIn or Google account to access programming functions. When this is done, an application for "Configurator" must be made (this is done via the window in the upper left corner) – go to App Settings, change from "User" to "Configurator", press apply!

The app contains all the relevant information and contextual help you need to use these simple functions.

## IR Interface for Smartphone – Fagerhult Art. no. 86279

The smartphone app communicates with sensor nodes in luminaires via IR communication from an interface connected to the device's headphone jack (3.5 mm). Always make sure to point the interface (dongle) at the sensor in the luminaire to be programmed.

The device is supplied with a USB charger. A blue LED indicates charging is in progress. When connecting to a smartphone or tablet, the volume will be raised fully. The volume will be reset when disconnecting the dongle. If the volume is adjusted while the dongle is being used, it will stop transmitting if the volume is below 50%.

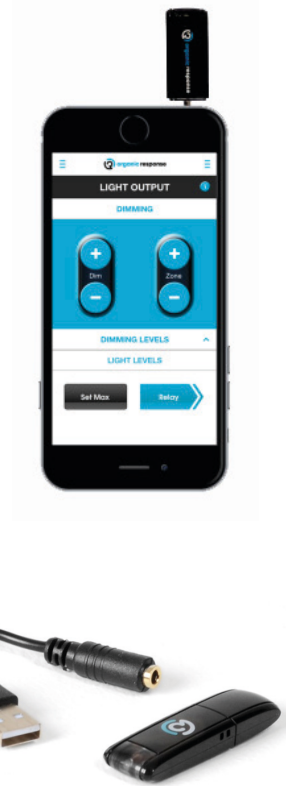

## Programmable functions

All features and functions can be changed with an app and connected dongle. The dongle communicates via infrared light, which is the same as between luminaires.

You can download the app from Google Play or the App Store. The dongle can be ordered from Fagerhult (Art. no. 86279). Access to all the app's functions is granted upon registration and log-in via LinkedIn or Google.

### Basic programmable functions:

- Temporary dimming in a luminaire
- Temporary dimming in a zone
- Change the maximum light level
- Change the time since last presence
- Change “personality” – default settings for different environments.
- Daylight dimming
- Adjust PIR sensor sensitivity
- Change the PIR sensor's behaviour upon presence detection (Auto or Manual activation)
- Program Scenes (can be reset on the touch panel)
- Adjust functions on the touch panel
- Behaviour when powered up
- Zoning – certain luminaires are not affected, e.g. difference between office and corridor.

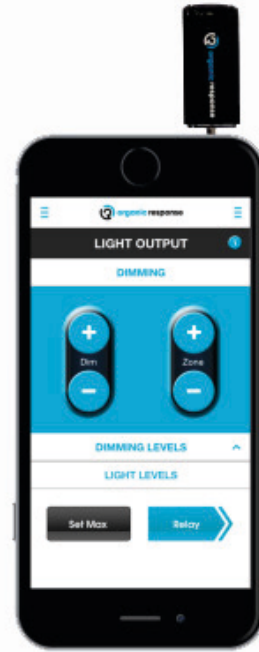

Smartphone with Dongle



### Using the app's functions

It is important to have an understanding of all the sections in the app when programming. You can always bring up more functions and information by swiping your finger from right to left or left to right. The function used to save settings can be found at the bottom of the app, together with the relay function (Relay). There is always more information to read directly in the app by clicking the (i) icon – see red arrow.

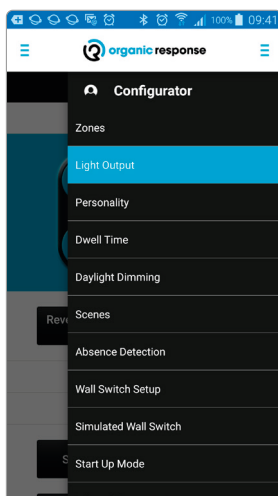

Menu from the right

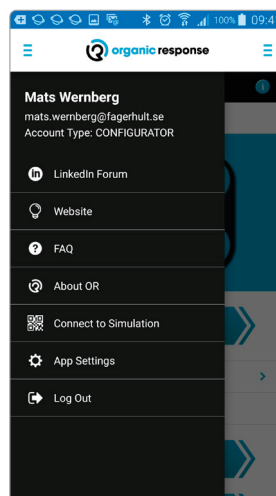

Menu from the left

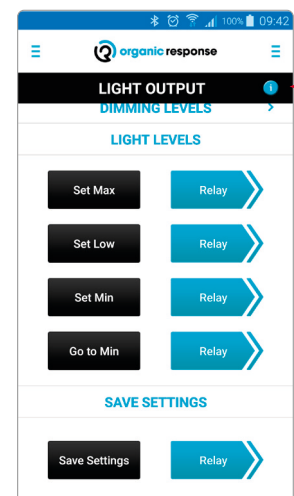

Menu from the bottom

## Times and light levels

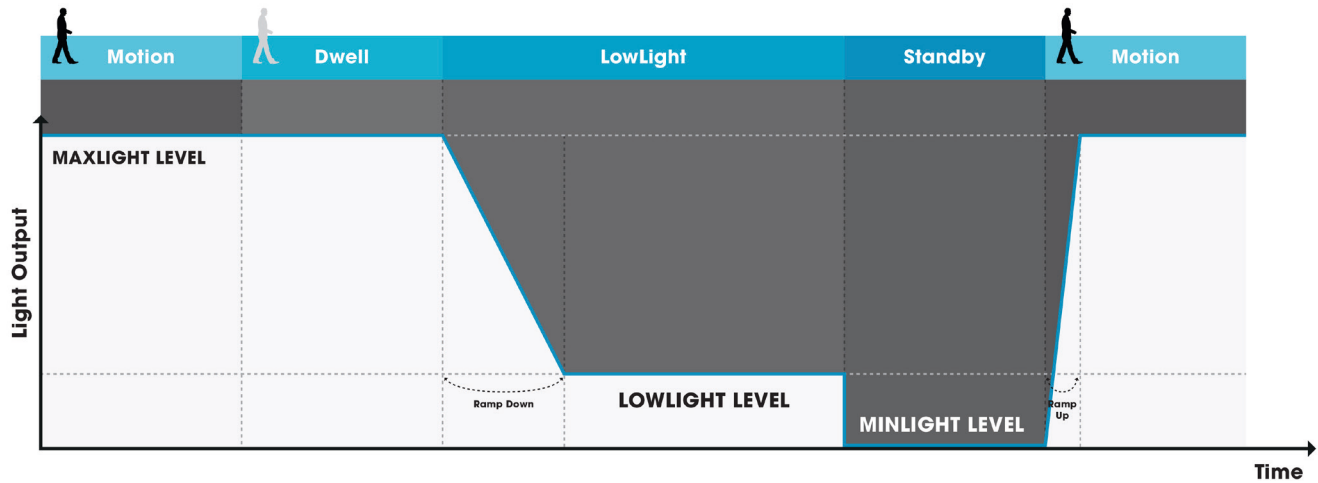

## Changing times and light levels

Various parameters can be changed to adapt the system to the environment in which it is installed.

- Presence. The light switches on at the set level. This function can also be blocked if you want to switch on the light manually.
- Time after last presence detected (Dwell Time). The duration the light should remain at the same level after last presence. Factory setting is 10 minutes.
- Lowlight Level. The level and time for which the light will indicate that it will switch off.
- If the light switches off completely or remains at a low level, each luminaire can be programmed individually (Minlight Level)

## Default settings (personality)

Times and lowlight level are saved in default scenes (personality). You can select a scene, save, and send on to other luminaires using the Relay function. This means you only need to program one luminaire, and then forward the information further.

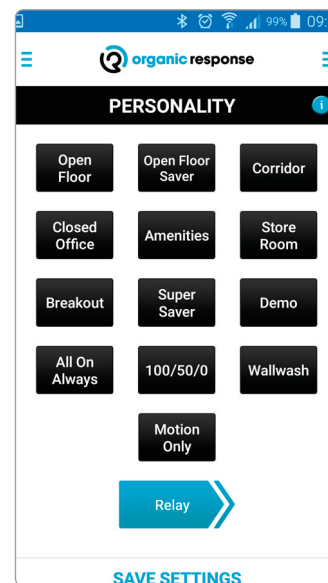

## Explanation of menu

Various parameters can be changed to adapt the system to the environment in which it is installed.

- Zones – option for placing luminaires into zones that DO NOT affect one another.
- Light Output – light level settings, max., min. and low level
- Personality – choice of default settings.
- Dwell Time – setting the time after last presence
- Daylight Dimming – setting the daylight dimming
- Scenes – 7 different scenes can be set.
- Absence Detection – automatic switch-on when presence is detected or manual switch-on (touch panel required).
- Wall Switch Setup – settings for touch panel, zoning, and IR strength.
- Simulated Wall Switch – simulated touch panel.
- Start Up mode – On/Auto or for a certain scene during presence
- Infrared Transmission – increases or decreases the transmission strength of a sensor.
- Sensor Node Settings – option to save settings in the app for use in other installations.
- Other Parameters – setting the PIR sensor’s sensitivity, fluorescent lamp burn-in time, etc.
- Disaster Recovery Mode – all light at full illumination for 90 minutes. Cannot be cancelled during the 90 minutes.
- Sensor Node Default Setting – refer to the table below.

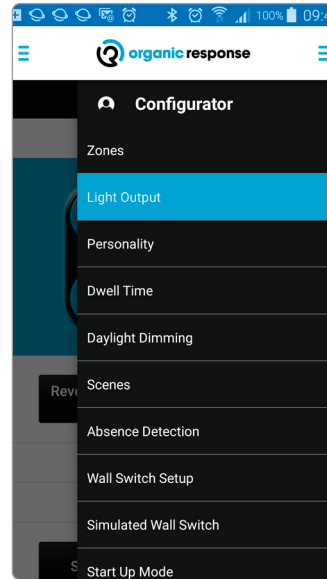

Menu from the right

## Factory settings

Full light	100 %
Lowlight level	0 %
Basic light level	10 %
Time after last presence	10 min.
Time at Basic Light Level	10 min.
Basic setting (personality)	Open Floor
Daylight dimming	Not enabled
PIR Sensor sensitivity	High
Fluorescent lamp burn-in time	Not enabled
Zoning (zone)	1
Scene 0 light level (on touch panel)	50 %
Scene 1 light level (on touch panel)	10 %
IR transmitting strength	30 %
Function at first start-up	Auto-sequence first 15 minutes. Test function

## Explanation of relay function

The Relay function facilitates the programming of multiple luminaires that will have the same setting.

For example, change the dwell time after last presence from 10 min to 20 min on one luminaire. Save the change with the app. You can now “relay” the setting to the other luminaires in the same zone. Press Relay. The programmed sensor will now flash once per second for 30 seconds. The other sensors will have a solid red light under the PIR sensor. This gives you time to ensure that all luminaires have received the information. After this, all sensors revert to normal operation, but with a 30-second change across the entire installation.

One function that cannot be used as above is luminaire zoning. For this, you will need to point the dongle at each luminaire that will change zone. If you have multiple luminaires, you can press the zoning button and hold it in while moving underneath the luminaires being programmed. The sensor will flash red.

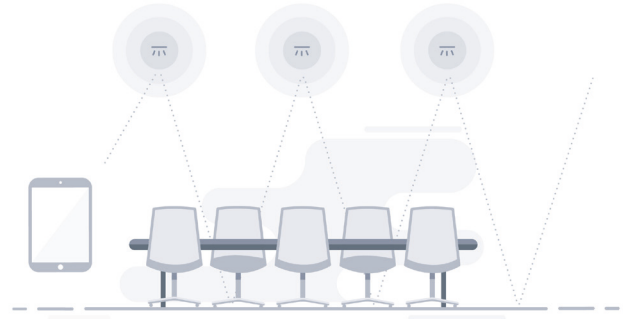



## Temporary dimming of a luminaire or zone

1. From the Light Output tab in the menu on the right, you can dim one luminaire at a time or an entire zone. Try pointing the dongle at a sensor and dimming the light. The buttons are labeled “DIM”. Dimming is temporary and resets once the system is switched off due to absence.
2. Point at the same sensor, but use the “ZONE” buttons to control light output in order for it to be relayed to other luminaires in the same zone. This is called relaying information between the sensors. Dimming is temporary and resets once the system is switched off due to absence.

### Light levels

1. Here you can adjust and save light levels for presence, for absence prior to switching off, and lowest level. If you have adjusted the light to the desired level for presence, you can save it using the “Set Max” button. After this, you can relay the setting to other luminaires in the same zone (they will immediately adjust to the same level as the first programmed sensor). The same procedure is used for other levels. With the Minlight Level function, you can also lock specific luminaires to constantly remain at a lowlight level. This can be used as a security feature in stairwells, lifts, or exits.
2. By saving the settings, you can reuse the same settings for other luminaires, e.g. on another floor or at a later date. You can use the Recall Settings feature to reuse the settings; refer to the chapter titled Recall Settings.

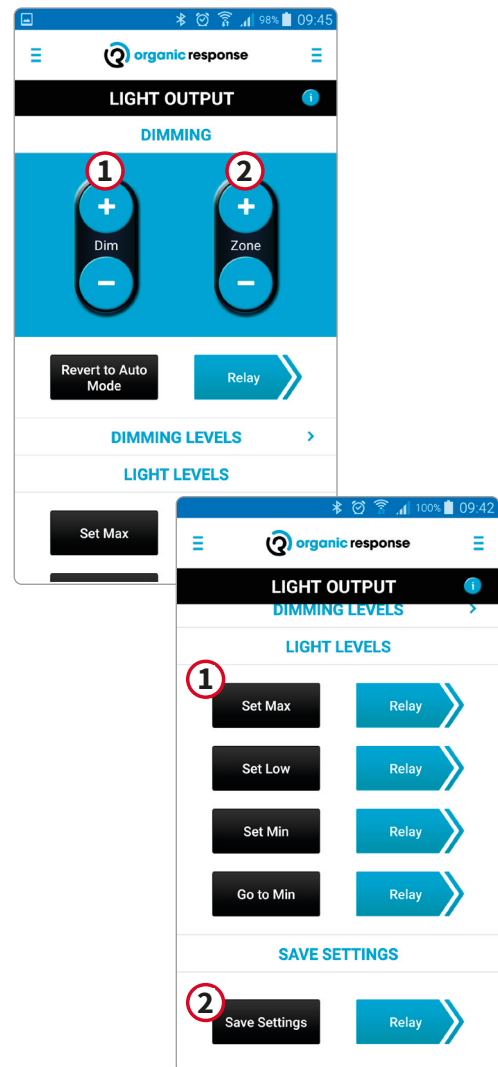

## Selecting a specific light value (Dimming Levels)

From the Light Output tab, you can also select a precise value for the different light levels: max., min., and low level. Finish by relaying to the zone’s other luminaires.

### Revert to Auto Mode

The “Revert to Auto Mode” function is used when programming scenes. The function enables you to leave programming mode and revert to normal operation.

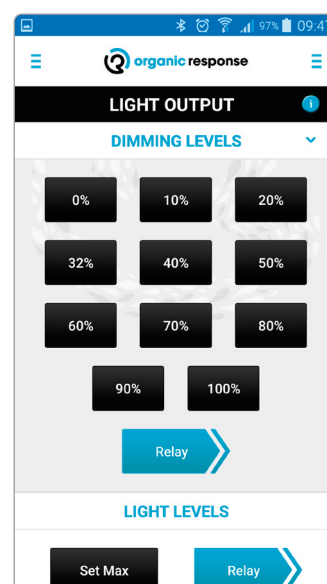

## Pre-programmed settings (personality)

From the Personality tab you can choose from a number of default “personalities” or function libraries. Each personality is selected for one type of environment and installation. The factory setting works for most environments, but especially for open-plan office landscapes. By installing the luminaires, then waiting to see how the setting functions, you will be able to determine which changes need to be made for an optimal installation. Not included is the setting for max. illumination, this should be done on location.

## Description of personalities

An important function in the default settings is how luminaires communicate with each other over distance. “Corridor” switches on multiple luminaires but at a lower level over distance.

- Open Floor – open-plan office landscape.
- Open Floor Saver – office landscape, but with fewer luminaires that switch on fully based in proximity to presence.
- Super Saver – huge saving potential in an office.
- Corridor – switches on multiple luminaires in order to illuminate the entire length of the corridor.
- Closed Office – only switches on a few luminaires in proximity to presence; can be supplemented with extended time after last presence.
- Amenities – suitable for rooms with low presence, such as toilets.
- Store Room – storage rooms, cloakrooms, etc.
- Breakout – suitable for office meeting spaces.
- Demo – used to demonstrate the system’s functions, short duration between presence and switch-off.
- All On Always – lights always on, never switch off.
- 100/50/0 – only a few luminaires switch on in proximity to presence. Greatest possible savings.
- Ripples – used to visualise how the presence and relay functions work.
- Wall Wash – illumination at 100% regardless of distance to detected presence.
- Motion Only – luminaires only react to presence; no IR information is relayed. For demonstrating the presence function.

## Saving a personality

Point the dongle at a sensor, select the desired function. Finish with “Save settings”.

If multiple luminaires are to have the same setting, use the relay function.

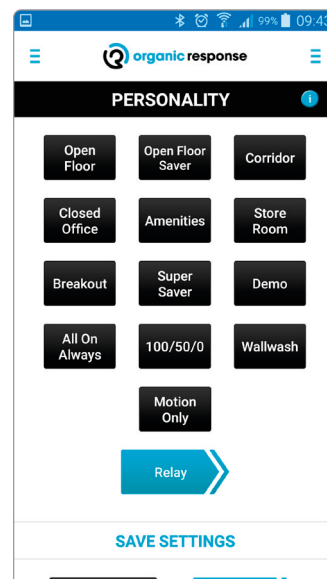

## Pre-programmed settings (personality)

A large part of “personality” is the relay of information via IR signals between nodes/luminaires. The whole concept of the Organic Response system is that, when presence is detected, it switches on multiple luminaires or only a few depending on the setting. The factory setting (Open Plan Office) switches on a large area, which means the light value in the luminaires decreases corresponding to presence detection (refer to image and table below).

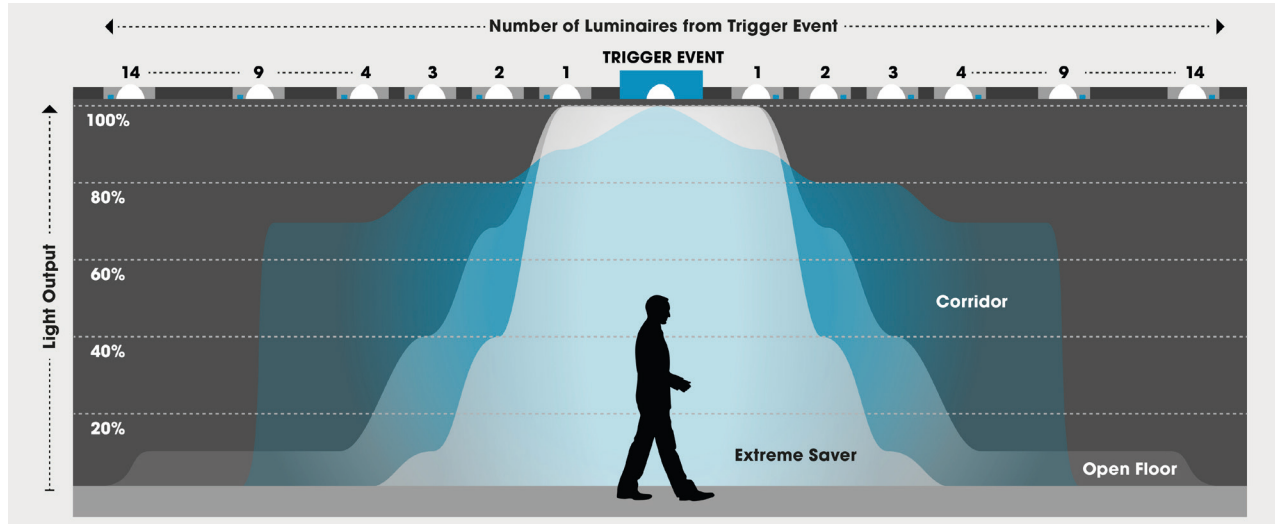

Description of the difference between three default settings (personality). Open Floor switches on the most luminaires, but they decrease in brightness according to distance. Corridor switches on fewer luminaires but at higher brightness.

Personality	Dwell Time (Mins)	Motion (MaxLight)	Light Levels (%)							0% from Level	Lowlight	Standby	Lowlight Time (Mins)
			Level 1	Level 2	Level 3	Level 4	Level 5	Level 6+					
Open Floor	10	100%	100%	70%	40%	10%	10%	10%	10%	16	10%	0%	10
Open Floor Saver	10	100%	100%	10%	10%	10%	10%	10%	10%	11	10%	0%	10
Corridor	10	100%	90%	80%	80%	70%	70%	70%	70%	11	10%	0%	10
Closed Office	15	100%	80%	10%	10%	0%	0%	0%	0%	5	10%	0%	15
Amenities	15	100%	50%	10%	10%	10%	10%	10%	10%	11	10%	0%	15
Store Room	10	100%	100%	80%	80%	0%	0%	0%	0%	5	10%	0%	15
Breakout	15	100%	100%	50%	10%	10%	10%	10%	10%	11	10%	0%	15
Super Saver	5	100%	100%	40%	10%	0%	0%	0%	0%	5	10%	0%	2
Demo	10s	100%	60%	40%	10%	10%	10%	10%	10%	11	10%	0%	5
All On Always	10	100%	100%	100%	100%	100%	100%	100%	100%	Never off	100%	100%	10
100/50/0	10	100%	50%	0%	0%	0%	0%	0%	0%	2	10%	0%	0
Ripples	10	100%	0%	100%	0%	100%	0%	0%	0%	5	10%	0%	2
Wall Wash	10	100%	100%	100%	100%	100%	100%	100%	100%	20	10%	0%	0
Motion Only	10	100%	0%	0%	0%	0%	0%	0%	0%	1	10%	0%	10

Description of each “personality” in detail. Level 1 – 6 + correspond to the light level at which a luminaire switches on when it receives IR signals from sensor nodes as detected presence. It is important to know that the IR signal can be reflected to several luminaires in proximity to the presence, which is why the description in the table may be considered somewhat extreme.

NOTE! If specific parameters have been programmed, such as Dwell time or Lowlight, will these remain even if you change "Personality".

## Setting the time after last presence detected (Dwell time)

After last presence is detected, a countdown time will begin in each node individually. The factory setting of this time is sufficient to not produce annoying phenomena or cause the luminaires to switch off. This time, and the time at low level prior to switch-off, can be set in Dwell Time in the menu. The factory setting is set to 10 minutes for both of these times (refer to the table for personality as applicable). Save and relay in Save Settings. A good tip is to use a default personality and then adjust the functions in detail.

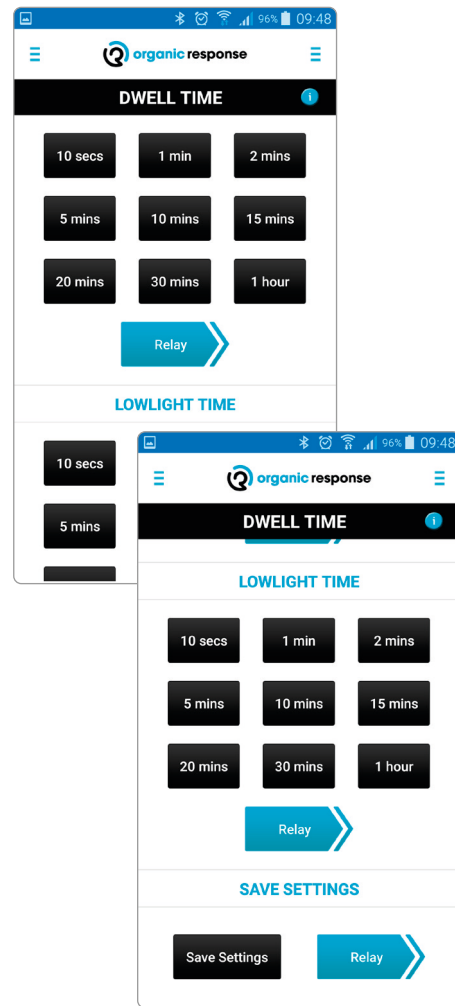

## Daylight Dimming

Daylight dimming is an effective way to optimise energy saving. For example, luminaires at windows in a large office can dim according to incident daylight. Luminaires farther into a room can be optimised by selecting the correct fixed light level. If luminaires that will use daylight dimming are in a separate zone, it is easier and quicker to make adjustments that apply to all. It's important that daylight dimming is adjusted when the effect of sunlight is not dominant, preferably below 5% of the amount of light measured with a lux meter. If the luminaires are able to provide approx. 700 lux without being affected by daylight, the level can be adjusted down to just over 500 lux, which is the recommended value for offices and workspaces.

## Setting Daylight Dimming

Use + and - in the Light Output tab to adjust the light level. Adjust all luminaires that use this function. Use + and - to adjust the entire zone in order for all luminaires to have the same level.

1. Point the dongle at a luminaire and press the Calibrate and Enable button.
2. Using the Relay button you can now initiate the process to adjust all nodes and read the desired light level.
3. Finish with Save Settings and Relay.

With Enable and Disable you can start/stop the function.

NOTE! Do not stand underneath a sensor when it is in calibration mode. It is also advisable to have the right furniture in place, so that the setting does not apply to the floor, but rather the work area.

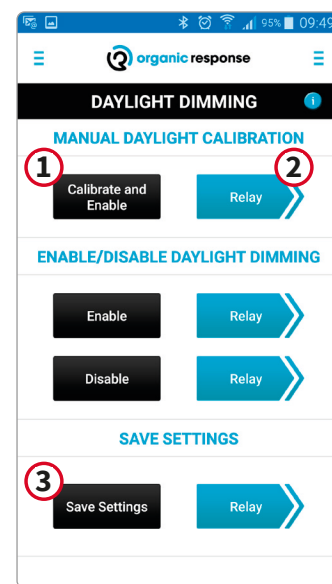

## Simulated Wall Switch

You can easily simulate the function of a touch panel from the Simulated Wall Switch tab. It gives an idea of the functions offered by the panel.

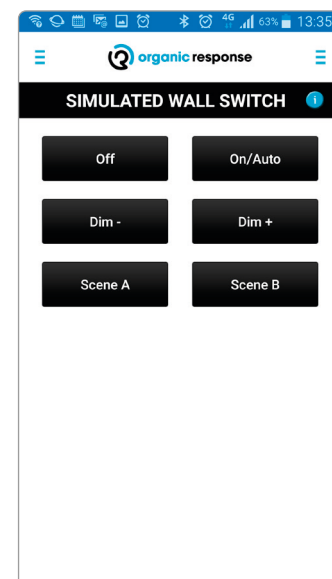

## Zoning (Zone)

You can easily zone luminaires and sensors so that the effect is not limited and optimised. Zoning and the choice of different “personalities” allow for a fast and reliable solution. Large offices and corridors can/should have different parameters for optimal functionality. Zoning luminaires is the only time that you will be required to point the dongle at each sensor and change the setting. Zoning cannot be relayed on. By adjusting the zone with + -, you can easily determine whether the function and zoning are correct. Remember that configuration of a zone is not relayed to other zones.

## Zoning example

All sensors/luminaires are zoned in Zone 1 upon delivery. The Zone tab in the app allows you to rezone one luminaire at a time. To rezone quickly, press and hold a zoning button while walking underneath all the luminaires (suitable for corridor). The luminaire to which you point the dongle will flash red 3 times.

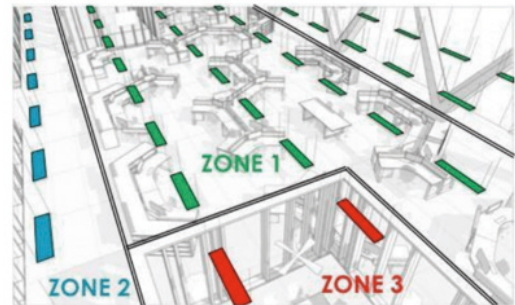

## One-way multi-zoning

In certain cases, such as in the example below, you will want presence in the office section to maintain a light level in the corridor. This function is suitable when there are fewer people in the office.

Choose the zone to be listened to, i.e. the corridor (Zone 2) will listen to the office (Zone 1).

Choose the zone to be listened to. See red arrow.

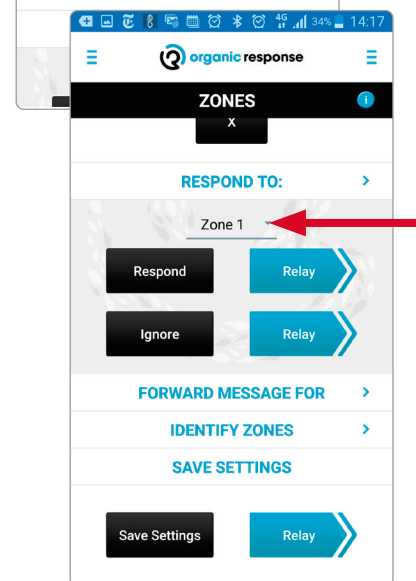
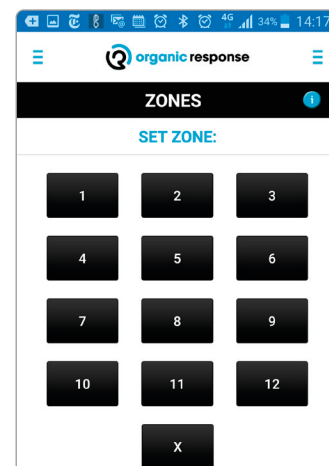
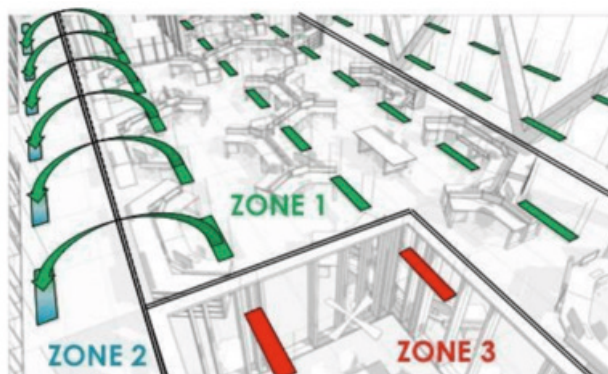

## Relay programming information (Forward Message For)

If necessary, you are able to forward information via a zone, which is not affected. As shown in the image below, programming commands in a corridor (Zone 2) will also affect nodes on the light in the second corridor beyond the office (also in Zone 2). The function is located under the “Zone” tab and “Forward message for”. Select the zone to be forwarded (in this case Zone 2) and program it to correspond to a few luminaires in Zone 1. You do not have to program all the luminaires in Zone 1, just a few to ensure the information is correctly relayed. Finish by saving the change. You can also remove links with the “Ignore” button.

Note: This is only for programming commands, not presence information.

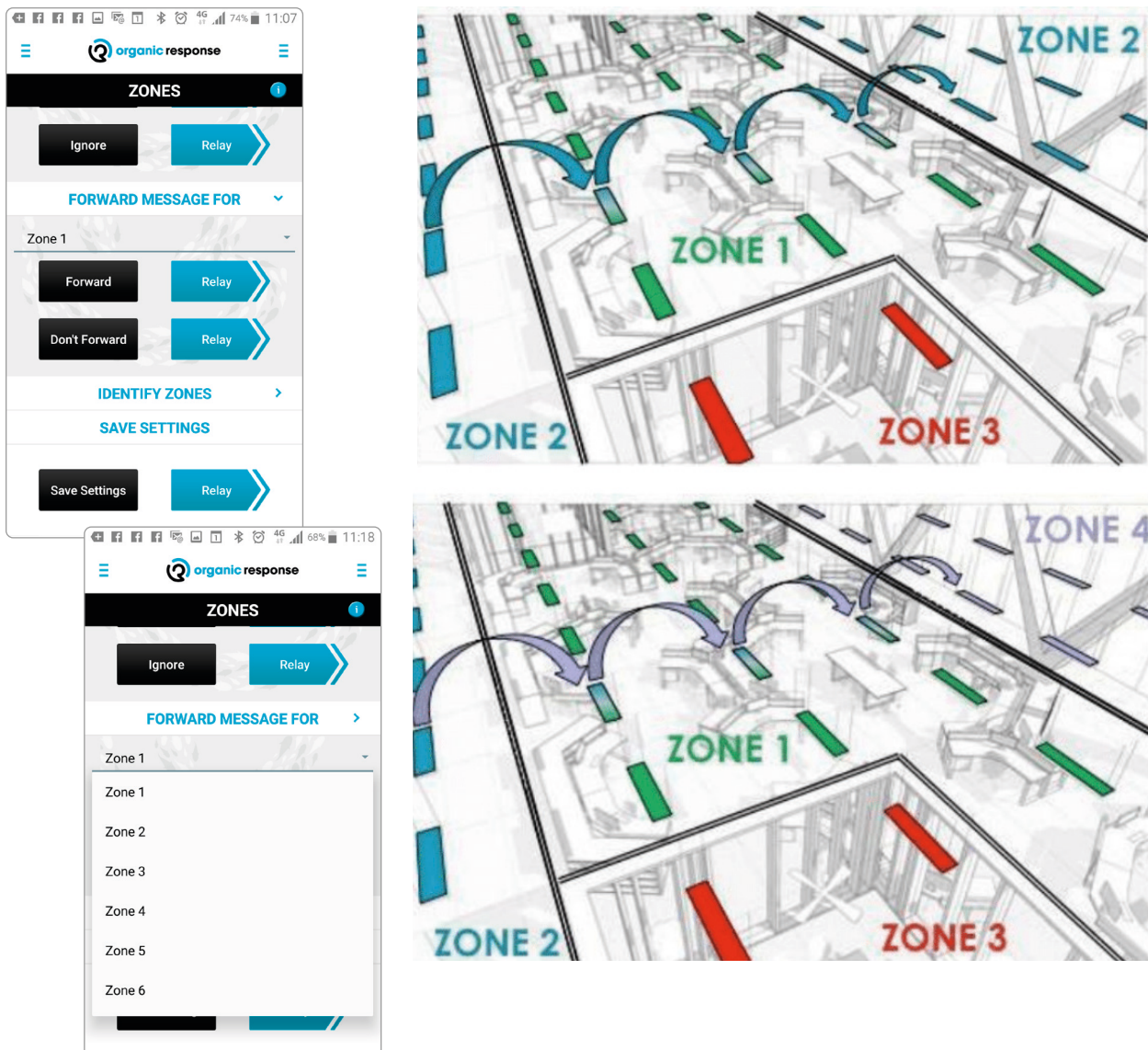

## Relay presence information (Forward Message For) via multiple zones

It is also possible to forward information via multiple zones. Use the same procedure to enable the luminaires to relay information on. It is important to know which zones are used. The reason is that there may be a touch panel located in the first corridor that will affect Zone 4 in the second corridor.

## Zone X

Zone X is used to send/receive commands from all other zones.

A good example is a large office in Zones 1-5, with luminaires for wall lighting along walls and pillars. When a person enters the room, one of the zones starts to switch on, but without Zone X the area farthest away from the presence would remain dark. By placing the wall-mounted luminaires in Zone X, they will react to commands from all zones, in this case Zones 1 up to 5. The result is that the wall lighting farthest away will switch on. This means that modern lighting requirements for office environments can be met.

In other words, Zone X reacts to commands from all zones. In this case, the positioning of glass sections between different offices and other room types is important. The function can also be used for general control from a touch panel, since if the panel is in Zone X, it affects all other zones.

## Identifying zones

Open the “Identifying zones” tab. Point the dongle at a sensor and press the selected zone button. If the sensor belongs to the same zone, it will turn red for 30 seconds, and other sensors in the same zone will also turn red. If the sensor only flashes, it is in another zone. Walk from zone to zone until the correct one is identified.

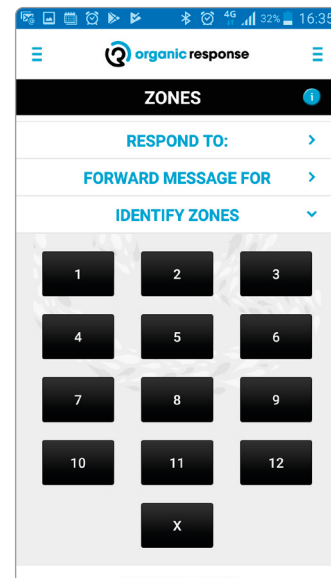



## Configuring Scenes

Lighting scenes can be used to select a specific light setting at a certain time. Selecting a scene stops active daylight dimming and presence detection. This is suitable for conference rooms and similar spaces. Each sensor can be adjusted separately to provide the required lighting. Lighting scenes are most easily recalled using the wall panel.

1. Select the “Scenes” function in the app. Use Configure Scene 0 (for example) to adjust the light from the luminaires. It is located on the wall panel’s “Scene A”.
2. Adjust the brightness of an luminaire, or for the entire zone.
3. Save the preferred setting.
4. Test the different scenes using the “Go to” buttons.
5. Under “Scene Functions” you can choose to revert to normal function (e.g. daylight dimming) with “Revert to Auto Mode”.

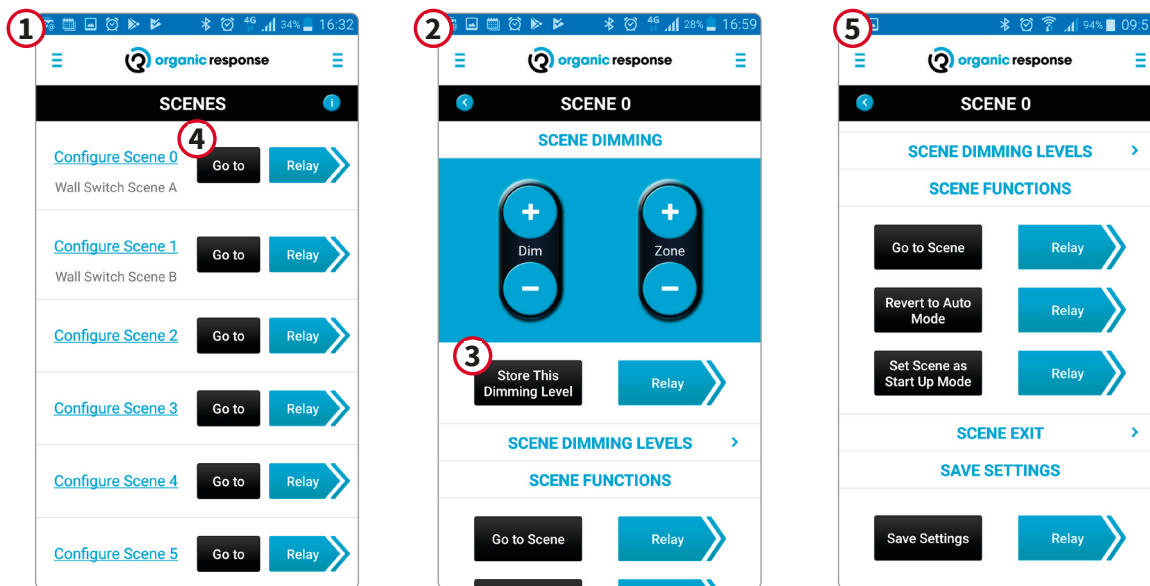

## Start Up Mode

The “Set Scene as Start Up Mode” function is used to determine what should happen after a power failure. When power is restored, you can check that the light does not switch on, or switches on in a predetermined mode. It may be a “hidden” scene that is not located on any touch panel.

If you have prepared a scene to operate at power start up, you can enable it in this menu. Point the dongle at the desired sensor, repeat for each luminaire, or use the relay function (relay).

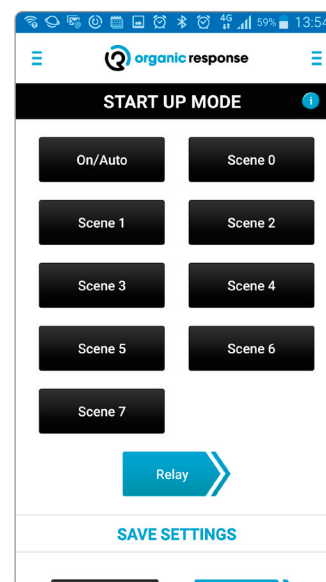

## Configuring scenes cont.

1. In this menu you can select precise % values in order to ensure that levels are equal in a luminaire zone.
2. Scene Exit can be considered a series of complex functions.
3. The “Remain in Scene Until On/Auto” function will remain active for a full year, provided that you do not press On/Auto on the touch panel, which reverts to normal operation, or use “Revert to Auto Mode” in the app, which also disables the scene.
4. The “Absence” function exists in order to be able to automatically revert to normal operation once presence detection no longer applies, and the time delay has elapsed. The light adjusts to low level, then switches off – now in normal operation.
5. Exit times are used to automatically exit the scene value and revert to normal operation. This is not contingent on presence.
6. The “Manual On/Auto Off” function is also referred to solely as Manual On. It disables automatic switch-on when a zone detects presence. The light must be switched on manually at the touch panel, or via the app. The light switches off as normal after last presence and according to the time setting. *NOTE! This function can only be used on nodes running version 160 or later.*

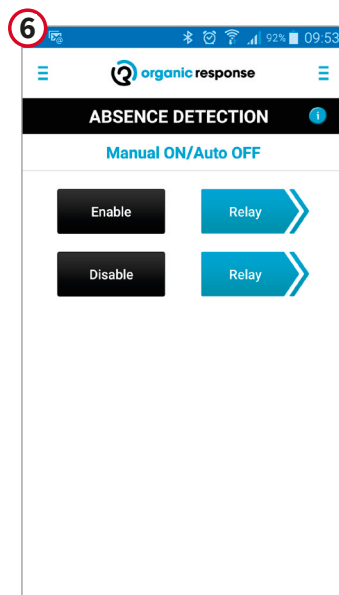
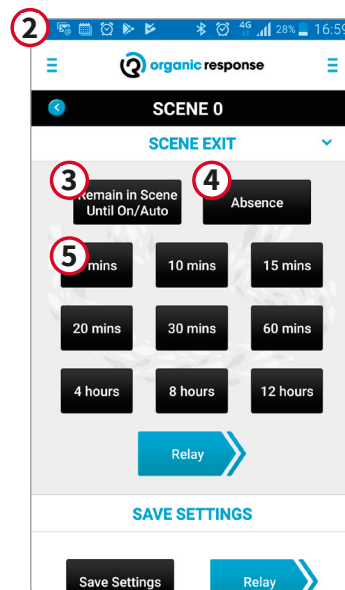
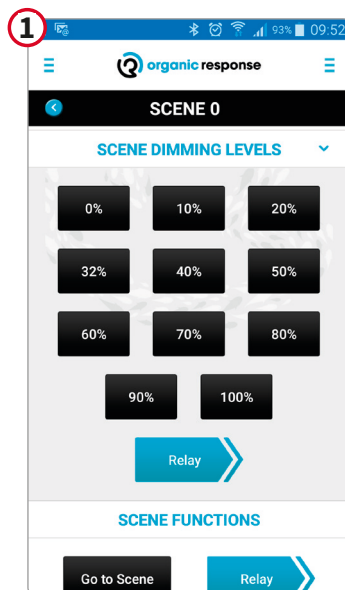

Point the dongle at a sensor and press the “Enable” button. If several luminaires are to have the same function, you can relay the setting.

This also applies to resetting the function.

*NOTE! This function can only be used on nodes running version 160 or later.*

## Organic Response Wall Panel

Organic Response can be controlled manually with a wall panel (Art. no. 86284). The panel is battery-powered and can easily be placed on a wall or even glass surfaces. Batteries are supplied with the device. The functions are easy to use. The panel is supplied to work directly with sensors in Zone 1, but can easily be reprogrammed to another zone.

It is important to remember that the panel is normally in Sleep Mode in order to save battery power. When you press a function, the panel activates and remains active for 5 seconds to allow the device to be reprogrammed, e.g. changing zones.

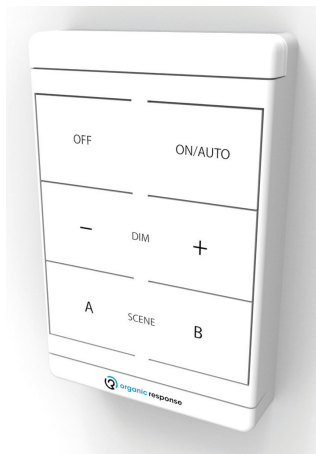
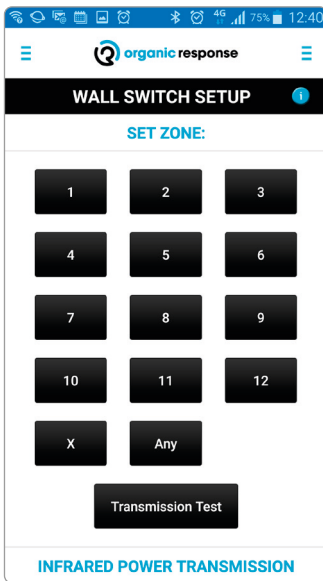

Select “Wall Switch Setup” from the app. Press any button to wake the panel (the top of the panel flashes blue when the command is sent).

Point the dongle at the panel and select which zone it will belong to. The panel flashes again to indicate that the change has been applied.

Test the panel for luminaires in the same zone.

“Transmission Test” is used to determine how far the IR signal reaches. Press the test button in the app and the panel will send 30 IR commands (2 per second for 15 seconds). All sensors receiving the command will flash 30 times.

If the signal is weak, the sensor will only flash a few times.

You can increase/decrease the IR signal strength using “Infrared Power Transmission”. Press the On button to wake the panel, select signal strength, and “Save Settings”.

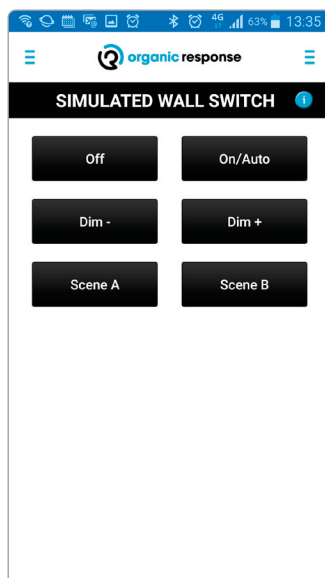
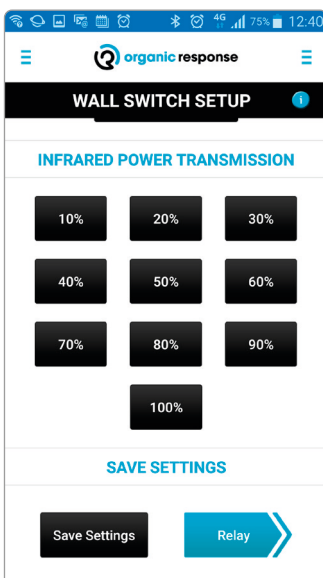

“Simulated Wall Switch”

This function allows you to simulate how a wall panel works without one being available.

## EnOcean wireless pushbutton panel

### Push Button configuration

Organic Response provides the opportunity to connect an EnOcean wall switch, which are battery-free and communicate wirelessly, with the Organic installation. The wall switch panels can be configured to control the selected zone, etc., all parameters are set using the Organic Response app for Android or iOS.

The wall switches are available with two or four button functions. The wall switch can be configured for a selection of functions via the app and “EnOcean Wall Switch Setup” in the menu. Refer to the figure below as a reference for the selection of function and position. The NFC function in the phone or tablet is used to transfer the selected settings in the app. This requires the phone or tablet to be held with the back against the panel so that the transfer can be performed securely. The app indicates when the transfer has been completed.

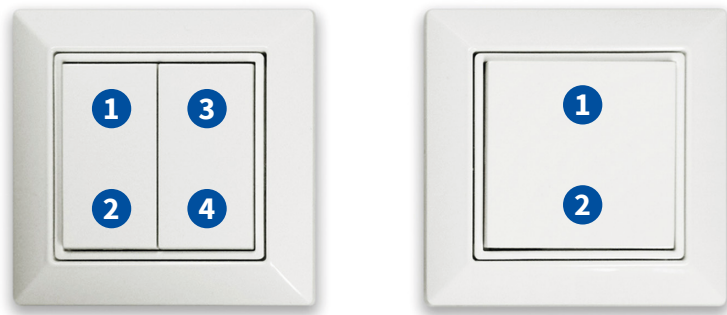

EnOcean Push Button Panel is available with two or four functions – (the numbers indicate only the position of the panel).

### How to configure an EnOcean Panel:

1. Open the Organic Response app and sign in with a “Configurator” approved Google- or LinkedIn account. See page 4.
2. Open “EnOcean Wall Switch” menu in the OR app.
3. Choose ”Zone Pairing” or “Switch ID Pairing” (there’s more information below on which settings are best suited for different application areas.)
4. Select 2 or 4 button panel.
5. Choose “Select function” from the following selection; On/Auto, Off, Dim up, Dim down, Scene 0 to Scene 6.
6. For ”Zone Pairing” choose which zone the push button panel will control. The default setting on the sensor nodes are Zone 1.
7. For “Switch ID Pairing One to One” functionality, tap the box “One to One Pair”
8. Press ”Configure” and hold the back of the phone or tablet against the wall switch. Note that the NFC-chips placement varies between different manufacturers and models.
9. Do not remove the phone or tablet until a message showing “Done” pops up in the app. If no message pops up, try moving the backside of the unit around until you’ve located the NFC-chip.
10. After configuring a wall switch a push on any button on the wall switch is needed before it starts working. This first push does not affect the light.

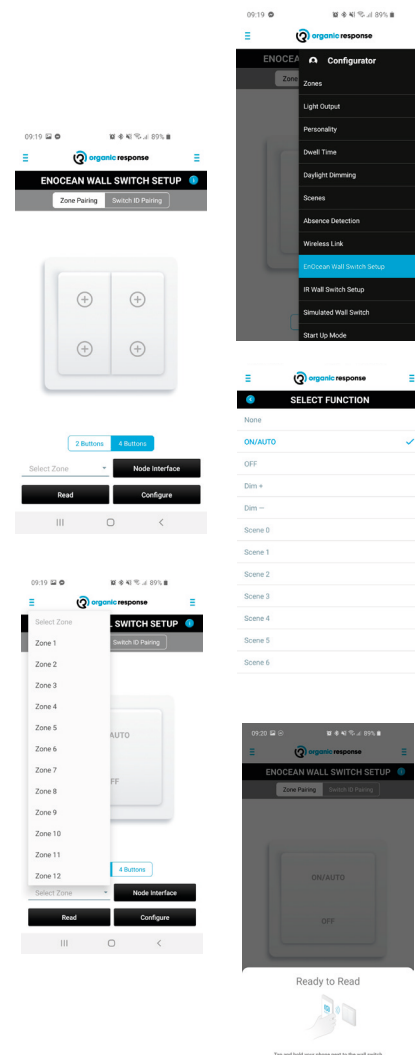

### Control “Dim Up & Dim Down”

This function is automatically available in the selection of “On/Auto” & “Off”. When “On/Auto” is selected, “Dim up” will automatically function as:

1. Quickly pressing the button switches on the light to the preset level “auto mode”
2. Pressing and holding the button will adjust the light level up, depending on how long the button is held down. It will continue to dim up for max 5s.

Similar function is available for the “Off” selection:

1. Quickly pressing the button switches the light off completely (Off is equal to scene 7 in this function).
2. Pressing and holding the button adjusts the light level downwards, depending on how long the button held down. It will continue to dim down for max 5s.

There are three different ways of configuring the communication between wall switch and sensor node in order to suit most application areas:

1. Zone Pairing
2. Switch ID Pairing
3. Switch ID Pairing One to One

## Zone Pairing

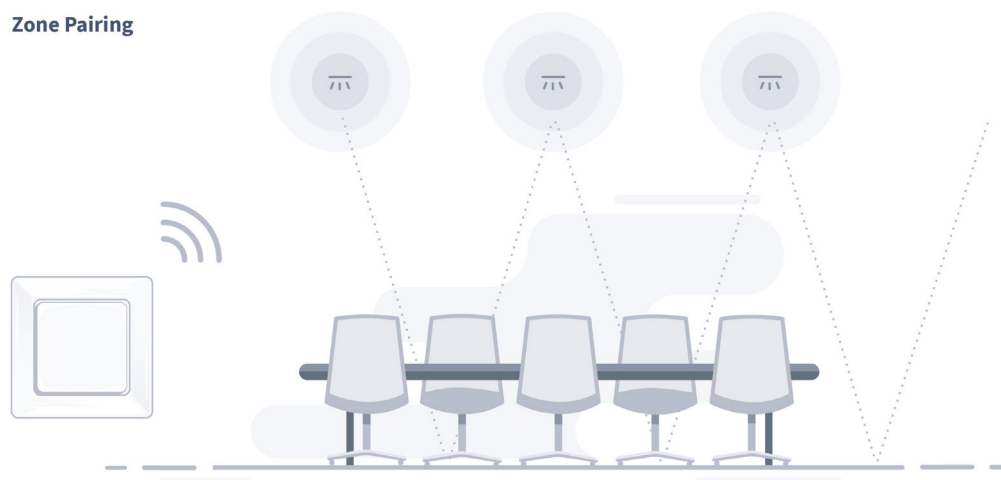

When using Zone Pairing the EnOcean wall switch communicates to all sensor nodes in the zone within radio range, about 10m. The sensor nodes then distribute the message via IR so the remaining nodes in the zone also receive the message. If no zone is selected, the switch will communicate to all sensor nodes within range regardless of which zones they belong to. This type of configuration is recommended in all types of installations when a fixed scene is to be sent from the switch e.g. ON/AUTO, OFF or SCENE 1. If continuous dimming is required in larger zones ( $\geq 9$  sensor nodes) it's recommended to use Switch ID Pairing instead of Zone Pairing.

### Note!

It is of most importance that SN3 nodes with FW (firmware) 175 or later are used. Earlier versions of SN3 nodes do not have this function. Use the Query function to see what version the node has (Note: Only works with iOS devices).

## Switch ID Pairing

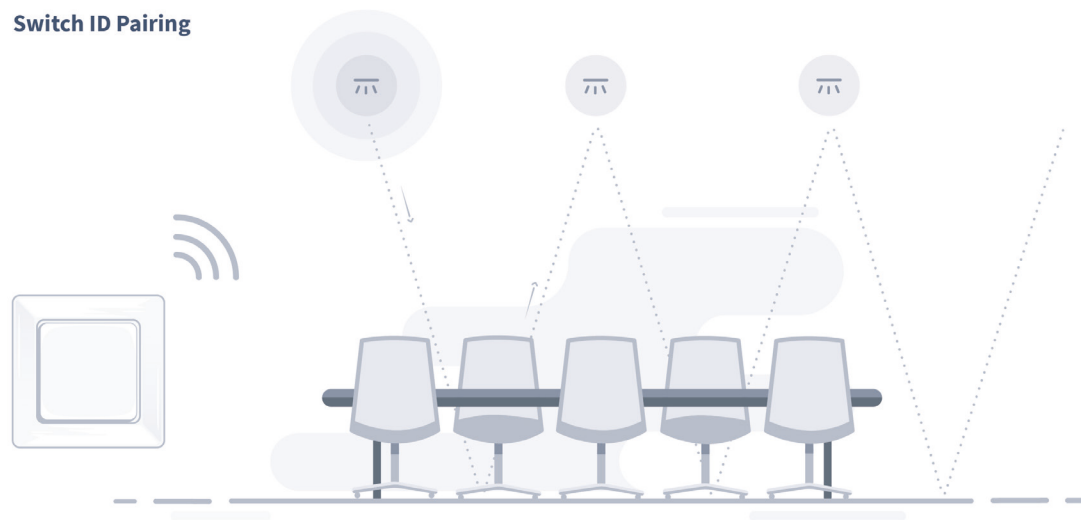

When using Switch ID Pairing only one sensor node is paired to the wall switch but the sensor node will still distribute the message via IR. There's no need to assign the wall switch to a zone, as it is the zone affiliation of the paired sensor node that determines which other nodes will receive the message. This configuration is best suited in larger installations ( $\geq 10$  sensor nodes) where you want to continuously dim the light up or down. Since the IR messages is distributed from a single sensor node, the risk of a message being copied is reduced and dimming becomes more stable. Because of this it's not recommended to pair more than one node within a zone to the same wall switch. For more information on how to pair a sensor node and a wall switch, refer to page 23 "Pairing with an EnOcean wall switch".

### Note!

It is of most importance that SN3 nodes with FW (firmware) 181 or later are used. Earlier versions of SN3 nodes do not have this function. Used the Query function to see what version the node has (Note: Only works with iOS devices).

## Switch ID Pairing One to One



”Switch ID Pairing One to One” is very similar to “Switch ID Pairing”. The only difference is that the paired sensor node/ nodes does not distribute the message on to other nodes via IR. This configuration is best suited when wanting to control one sensor node individually within a large zone e.g. an open office area. It’s possible to pair more than one node within the wall switches range (about 10m). Since no messages is sent via IR the lighting control is very stable on the paired luminaires.

**Note!**

It is of most importance that SN3 nodes with FW (firmware) 181 or later are used. Earlier versions of SN3 nodes do not have this function. Used the Query function to see what version the node has (Note: Only works with iOS devices).

When using Switch ID Pairing or Switch ID Pairing One to One you need to pair the EnOcean wall switch with one or several sensor nodes.

1. Start by configuring the wall switch with the right functions according to the steps on page 20.
2. If “One to One” functionality is to be used, tap the box in the app. Note that after a successful pairing you can easily switch between these configurations by only reconfigure the wall switch with NFC, no new pairing is needed.
3. Open the menu “Node Interface”.
4. Point the IR-Dongle towards the sensor node and press “Prepare to Pair”. The sensor node is now ready for pairing for 60s which is indicated by the dome turning red.
5. Press any button on the wall switch three times within this time to pair.
6. A successful pairing is indicated when the sensor node flashes red twice. A failed pairing is indicated when the sensor node flashes three times.

You can pair an EnOcean wall switch to more than one sensor nodes simultaneously. There’s no limitation in number of paired nodes to one wall switch. The switch can only communicate with paired nodes within range of the RF (around 10m).

#### Note!

A sensor node can be paired to a maximum of two different wall switches.

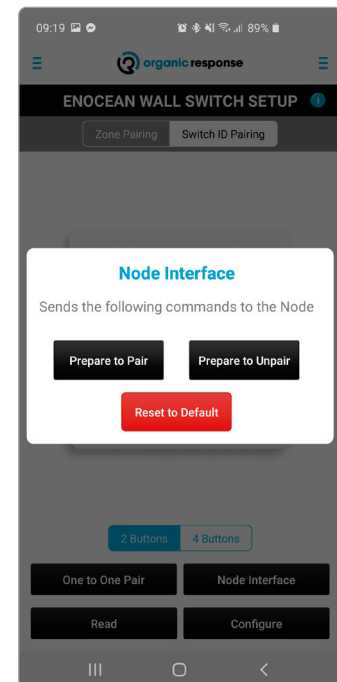

## Delete Pairing

It is also possible to erase the pairing between a sensor node and an EnOcean switch. This can be done in two ways.

### Prepare to Unpair

1. Point the IR-Dongle towards the sensor node and press “Prepare to Unpair”. The sensor node is now ready to delete a paired switch for 60s which is indicated by the dome turning red.
2. Press any button on the wall switch three times within this time to unpair.
3. A successful pairing is indicated when the sensor node flashes red twice. A failed pairing is indicated when the sensor node flashes three times.

### Reset to Default

1. Point the IR-Dongle towards the sensor node and press “Reset to Default”. This function will return the node to its “Default state” which is Zone pairing mode. This function, whether the node is in Zone Pairing mode or Switch ID Pairing Mode, will also erase any pairing between the sensor node and an EnOcean wall switch.



## Read an EnOcean Wall Switch

From the app's menu you can also download information from a panel about how it is was previously configured. This can help you to set the same configuration on additional panels. However, remember that when navigating to another function in the app's menu, you lose the previously downloaded information.

1. Press "Read" in the "EnOcean Wall Switch Setup" menu.
2. Hold the back of the device against the wall switch. Note that the NFC-chips placement varies between different manufacturers and models.
3. After a Successful reading the wall switches previous settings is shown in the app.

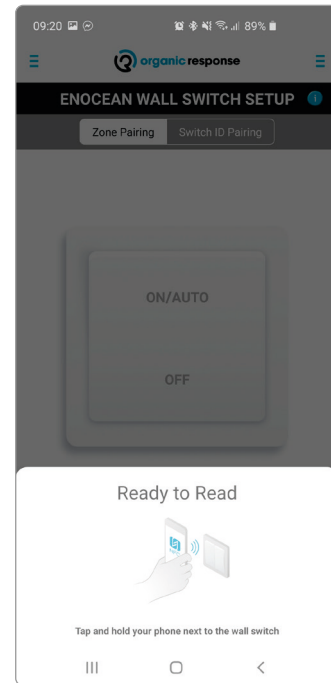

## Factory reset EnOcean Switch

If there is a need for a factory reset of pushbutton, this can be done on site using the steps below:

1. Enter the "EnOcean Wall Switch Setup".
2. Select "Zone Pairing".
3. Make sure no zone is selected. It should say "Select Zone".
4. Insert the settings using NFC by pressing Configure and hold your phone against the button.
5. Remove the rocker(s) and the switch housing.
6. Press all four buttons while pressing down one of the energy bows. The energy bow must be held down for at least 10 seconds. The four buttons does not need to be held for 10 seconds but can be released when the energy bow is pressed down.

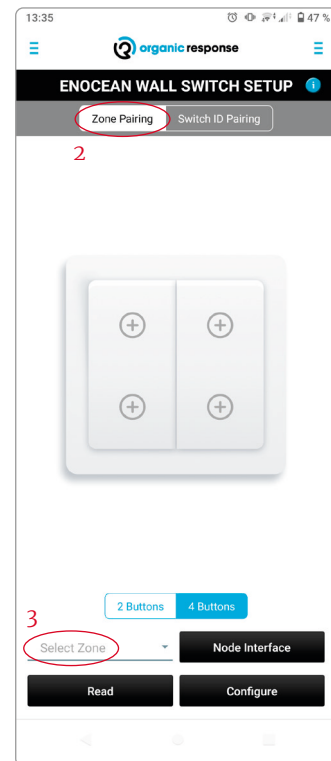
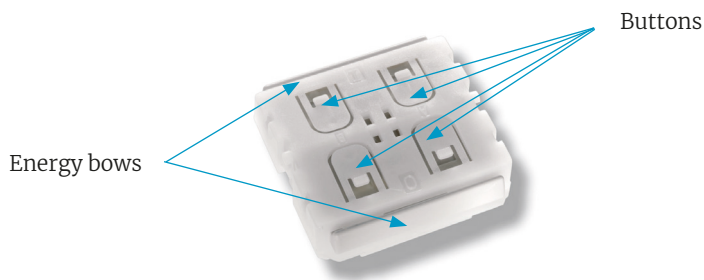

## Wireless communication between nodes without IR link

Nodes belonging to the same zone but unable to communicate due to physical barriers can be programmed to use the wireless communication to transmit further presence information and changed settings. This can be used in situations where a group of nodes in the same zone is separated by physical barriers that prevent IR messages from being propagated over physical barriers.

### NOTE

It is of most importance that SN3 nodes with FW (firmware) 175 or later are used. Earlier versions of SN3 nodes do not have this function. Used the Query function to see what version the node has (Note: Only works with iOS devices).

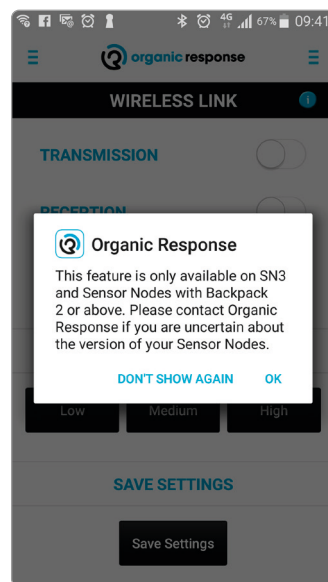

Information about what node version this is available for.

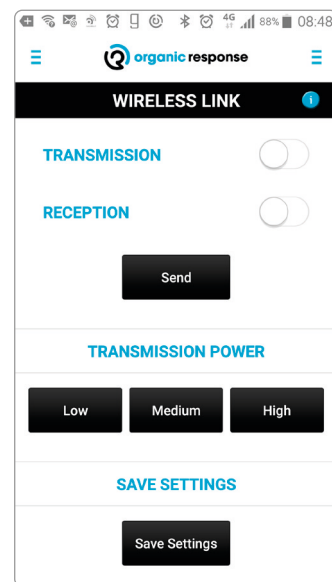

Settings on enable/disable transmission and reception and adjustments of signal strength

### Any Sensor Node can be configured to:

**Transmit** occupancy or configuration message via Bluetooth Low Energy (BLE), and/or **Receive** any occupancy or configuration message via BLE.

There is no one-to-one pairing involved. This means that any Receiver that can receive the message sent by a Transmitter will act on those messages as long as both transmitter and receiver are in the same zone or linked to share messages. Note that BLE has a long range. To limit (or extend) the BLE range, the Transmission Power can be adjusted.

### Configuring the node

The sliders can be used to:

- Enable Transmission only while reception is disabled
- Enable Reception only while the transmission is disabled
- Enable both transmission and reception
- Disable both transmission and reception

Then press the Send button for either of above to be implemented while pointing the dongle towards the sensor node.

To configure Transmission Power, press the button for the desired level while your dongle is pointed towards the sensor node.

The Query button will pop up a message displaying the current settings. (Note: Only works with iOS devices).

### Save Settings

Only applicable to enabling and disabling of the transmission/reception, however, the transmission power is always saved automatically without having to press save.

## Infrared Transmission

If you suspect that the IR signal from one sensor to another is too weak, or is not being reflected adequately, you can perform a transmission test. Point the dongle at a sensor node and press “Transmission Test”. The node at which the dongle is pointed will flash red twice per second for 15 seconds, while the receiving node will flash red for approx. 30 seconds. If a node has poor reception, it will only flash a few times. In such a case, it is necessary to amplify the out signal from the node sending the commands. Use the app to adjust the strength of the IR signal.

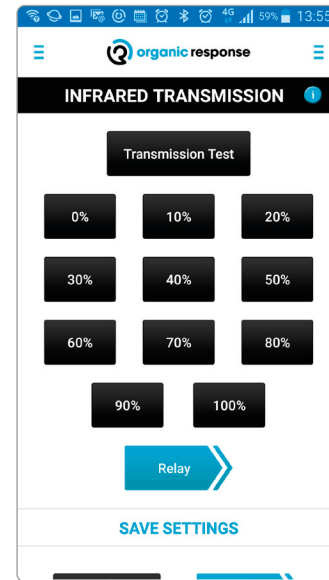

## Sensor Node Settings

Three choices can be made from this menu:

“Save Settings” saves all settings made for a specific node or the zone it belongs to.

“Recall settings” recalls all settings made for a specific node or the zone it belongs to.

“Recall Factory Default Settings” resets the factory settings for a node or the zone it belongs to. Factory settings can be found earlier in this manual.

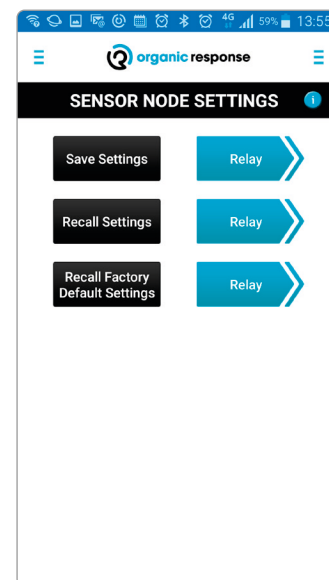

## Other parameters

Here you can adjust sensor sensitivity settings.

“Motion Sensitivity” – A highly sensitive PIR sensor may detect heat sources that do not display the correct movement, i.e. any type of heat source such as, ventilation, a photocopier, curtain, etc. By increasing or decreasing the sensitivity you can avoid this type of problem.

“Burn in Mode” – This function locks the system at 100% for 100 hours, which is a sufficient amount of time for new fluorescent tubes to burn in. This function must not be used for other light sources.

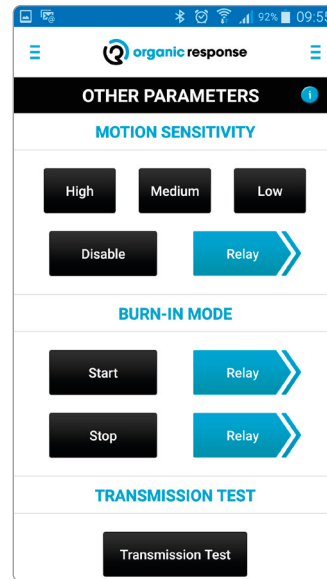

“Firmware Interrogation” – This function is not used in a working system, but exists to help retrieve diagnostics from a node if there have been problems. The function must only be used together with servicing personnel from Fagerhult.

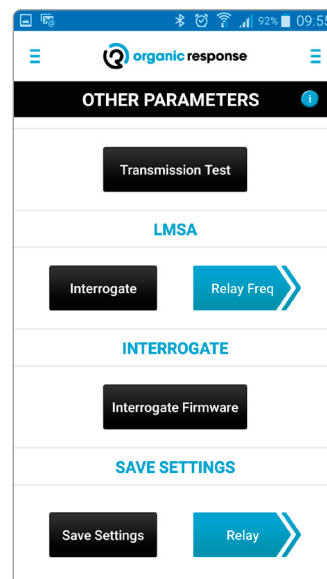

## “Disaster Recovery Mode”

This function can seem more alarming than it really is.

The function forces all sensors to maintain illumination at 100% for 90 minutes. The function can only be recalled by cutting power to the luminaires. After the 90 minutes, the sensor reverts to normal function, or according to their most recent programming.

*NOTE! This function can only be used on nodes running firmware 160 or later*

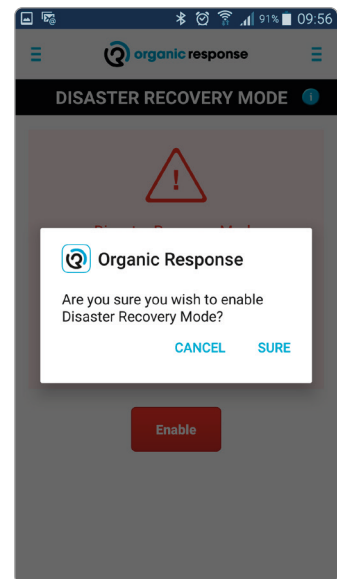
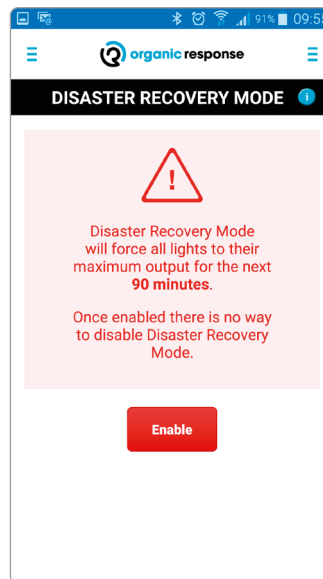
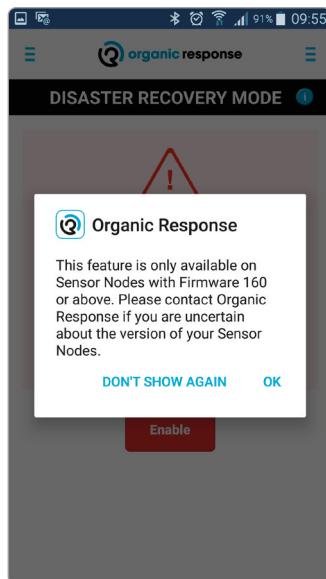

**FAGERHULT**

[www.fagerhult.com](http://www.fagerhult.com)